



DATA SHEET

SCN0080G 80-Segment Dot-matrix STN LCD Driver

To improve design and/or performance,
Avant Electronics may make changes to its
products. Please contact Avant Electronics
for the latest versions of its products

80-Segment Dot-matrix STN LCD Driver

1 GENERAL

1.1 Description

The SCN0080G is an 80-segment dot-matrix STN LCD driver. It is designed to be paired with the SCN6400G 64-common driver.

1.2 Features

- 80-output segment driver for dot-matrix STN LCD.
- Display duty : 1/8 to 1/128
- Display-OFF function for reducing power consumption.
- 4-level external LCD bias voltage.
- 4-bit parallel or serial interface with a controller for display data.
- Capability of being cascaded in application to expand segment number.
- Operating voltage range (control logic): 2.7 ~ 5.5 volts.
- Operating voltage range (LCD bias voltage, $V_{DD}-V_{EE}$): 8 ~ 20 volts.
- Data transfer clock: 6.0 MHz, when $V_{DD}= 5$ volts.
- Operating temperature range: -20 to +85 °C.
- Storage temperature range: -40 to +125 °C.

1.3 Ordering information

Table 1 Ordering information

TYPE NUMBER	DESCRIPTION
SCN0080G-LQFPG	LQFP100 Green package.
SCN0080G-QFPG	QFP100 Green package.
SCN0080G-LQFP	LQFP100 package.
SCN0080G-QFP	QFP100 package.
SCN0080G-D	tested die.

80-Segment Dot-matrix STN LCD Driver

2 FUNCTIONAL BLOCK DIAGRAM AND DESCRIPTION

2.1 Functional block diagram

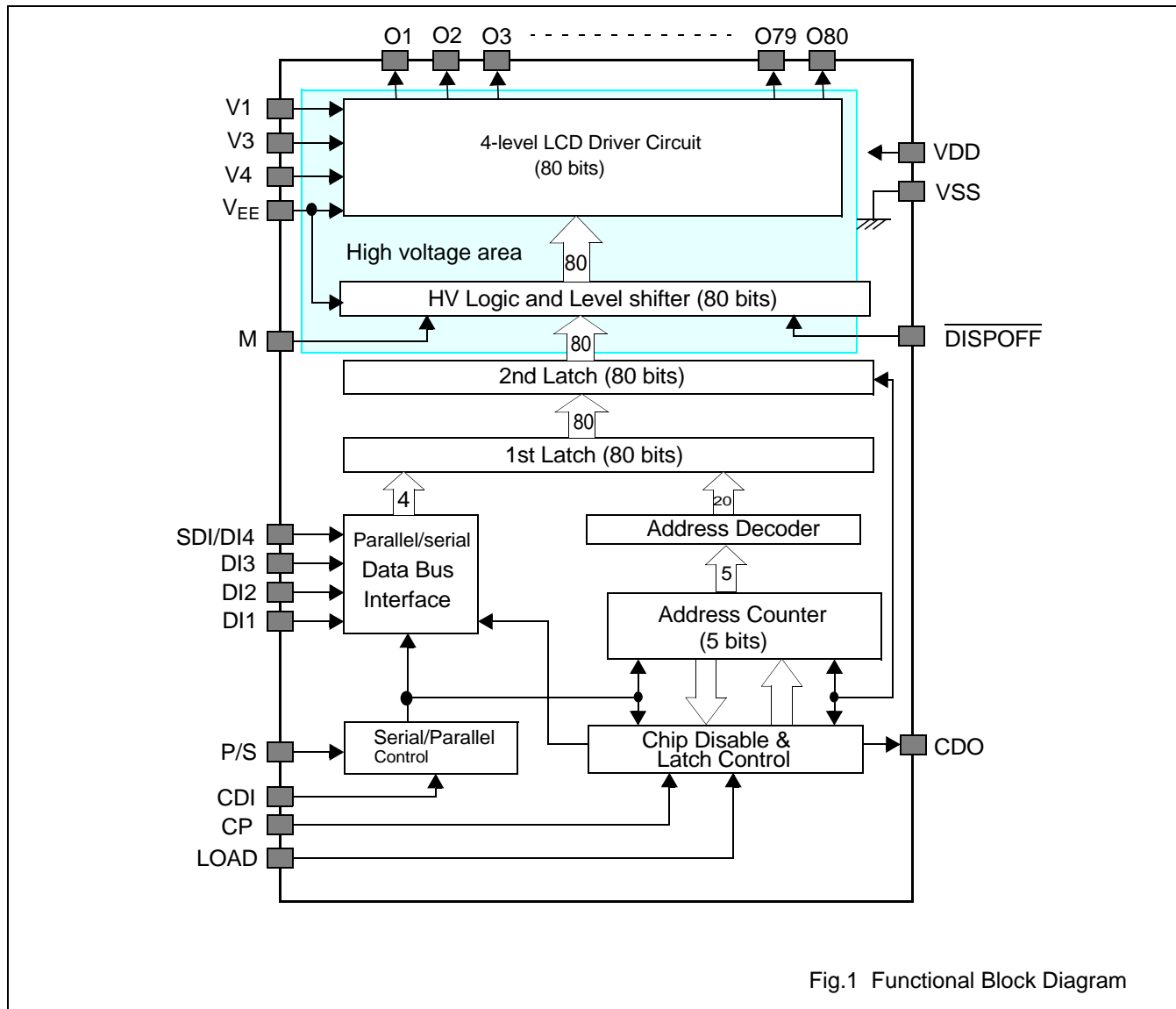
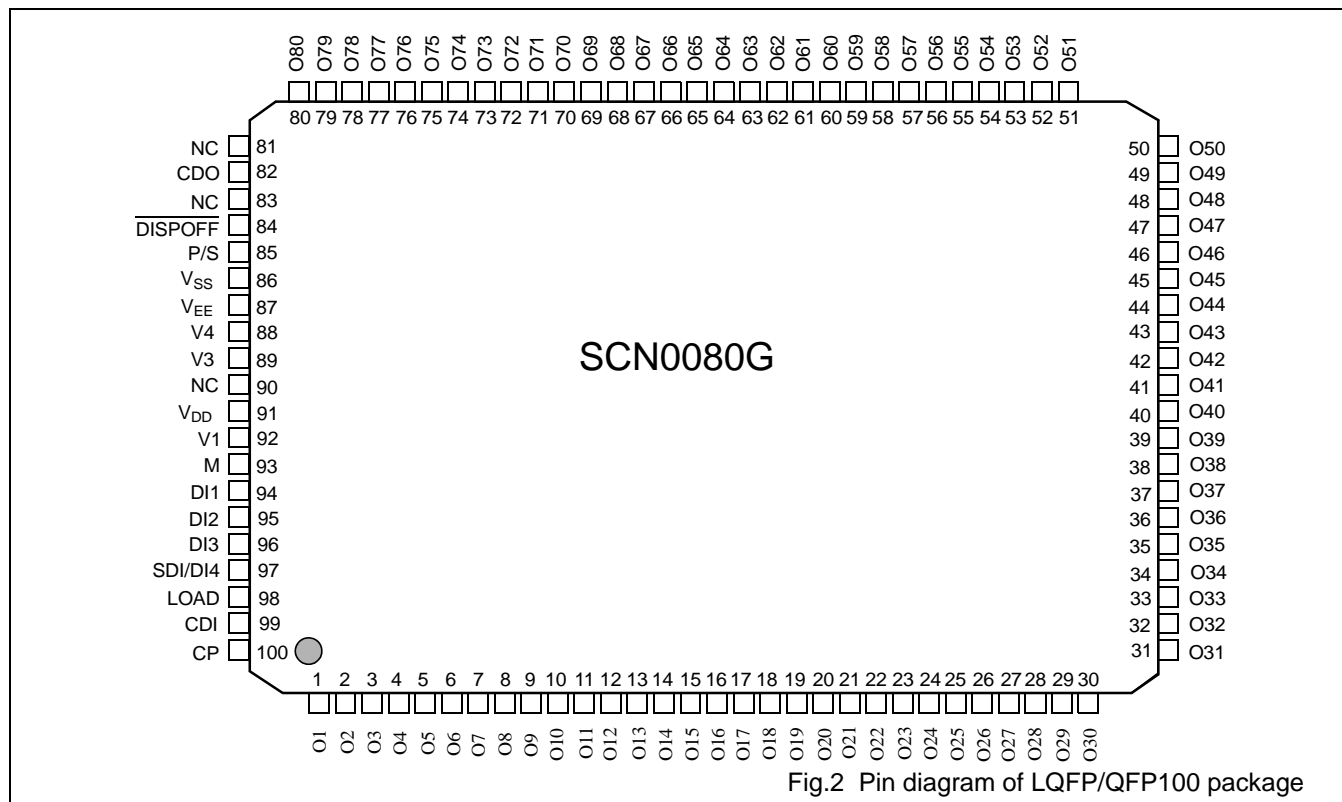

Fig.1 Functional Block Diagram

80-Segment Dot-matrix STN LCD Driver

3 PINNING INFORMATION

3.1 Pinning diagram



80-Segment Dot-matrix STN LCD Driver

3.2 Signal description

Table 2 Pin signal description.

To avoid a latch-up effect at power-on: $V_{SS} - 0.5\text{ V} < \text{voltage at any pin at any time} < V_{DD} + 0.5\text{ V}$.

Pin number	SYMBOL	I/O	DESCRIPTION
SCN0080G			
1~80	O1~O80	Output	Segment driver output. Please refer to Table 3 for output voltage level.
99	CDI	Input	Chip Disable pin. When CDI=High, on-chip data reception circuit is disabled and data can not be sent into the SCN0080G. When CDI=LOW, data can be sent into the SCN0080G.
92, 89, 88	V1, V3, V4	Input	LCD bias voltage. V1 and V_{EE} are selected levels. V3 and V4 are unselected levels.
87	V_{EE}	Input	Negative power supply for LCD bias.
93	M	Input	Frame signal, for generating alternating LCD bias voltages.
98	LOAD	Input	Display data (80 bits) latch clock. At the falling edge of the LOAD signal, 80-bit segment data is transferred from the first latch to the second latch for output. (Refer to Fig. 1, Functional Block Diagram.
86	V_{SS}	Input	Ground.
84	$\overline{\text{DISPOFF}}$	Input	Display Disable. When $\overline{\text{DISPOFF}}=L$, the outputs O1~O81 are all at a fixed level of V1.
91	V_{DD}	Input	Power supply for control logic.
85	P/S	Input	Selection of parallel or serial interface with a controller. When P/S= HIGH, 4-bit parallel interface is selected. When P/S=LOW, serial interface is selected.
81, 83, 90	NC		No Connection. These pins are not used in application and must be left open.
97, 96, 95, 94	SDI/DI4 ~ DI1	Input	4-bit parallel data input or 1-bit serial input. When 4-bit parallel data bus interfaces is selected, the 4 bits of data are latched into the SCN0080G at the falling edge of the CP clock. Please refer to Fig 3. When 1-bit serial interface is selected, data is input to the SDI/DI4 pin. In this interface mode, DI1~DI3 should be tied either to HIGH or to LOW.
100	CP	Input	Display data latch clock. 4 bits of display data (DI1~DI4) are latched into the internal 80-bit latch at the falling edge of CP. Please refer to Fig 4.
82	CDO	Output	Cascading output when the SCN0080G is used in cascade.

80-Segment Dot-matrix STN LCD Driver

4 FUNCTIONAL DESCRIPTION

4.1 Segment output drive (O1~O80)

The voltage level of the outputs O1~O80 is determined by Input data (display data), M (frame signal), and $\overline{\text{DISPOFF}}$, as given in the following table.

Table 3 output voltage level of O1~O80

M	Data	$\overline{\text{DISPOFF}}$	Output
L	L	H	V3
L	H	H	V1
H	L	H	V4
H	H	H	V _{EE}
X	X	L	V1

In the above table, X= don't care and must be tied either to H or L.

4.2 Display Data Inputs (DI1~DI4)

The SCN0080G has a 4-bit parallel data bus (DI1~DI4) to interface with a controller. A logic High of a bit represents an ON cell (black pixel on the LCD screen).

Table 4 Data bits

Display data	LCD drive output	LCD display
H	Selected level (V1, V _{EE})	ON
L	Unselected level (V3, V4)	OFF

4.3 Sequence of data input when 4-bit parallel interface is selected.

When 4-bit parallel interface mode is selected, the 4-bit data that is first latched goes to O77 ~ O80 and the 4-bit data that is last latched goes to O1 ~ O4.

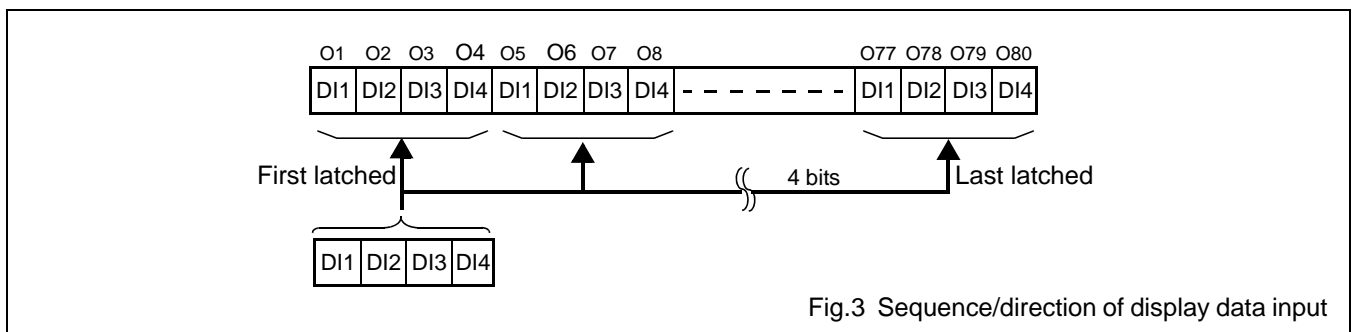

Fig.3 Sequence/direction of display data input

80-Segment Dot-matrix STN LCD Driver

5 ABSOLUTE MAXIMUM RATING**Table 5** Absolute maximum rating

$V_{DD} = 5\text{ V} \pm 10\%$; $V_{SS} = 0\text{ V}$; all voltages with respect to V_{SS} unless otherwise specified; $T_{amb} = 25 \pm 2^\circ\text{C}$.

SYMBOL	PARAMETER	MIN.	MAX.	UNIT
V_{DD}	Voltage on the V_{DD} input	-0.3	+7.0	V
$V_{DD}-V_{EE}$	LCD bias voltage, note 1	0	22	V
$V_i(\text{max})$	Maximum input voltage to input pins	-0.3	$V_{DD} + 0.3$	V
T_{amb}	Operating ambient temperature range	-20	+ 85	$^\circ\text{C}$
T_{stg}	Storage temperature range	-40	+125	$^\circ\text{C}$

Note:

1. The condition $V_{DD} \geq V1 > V3 > V4 > V_{EE}$ must always be met.

80-Segment Dot-matrix STN LCD Driver

6 DC CHARACTERISTICS

Table 6 DC Characteristics

$V_{DD} = 5\text{ V} \pm 10\%$; $V_{SS} = 0\text{ V}$; all voltages with respect to V_{SS} unless otherwise specified; $T_{amb} = 25 \pm 2\text{ }^\circ\text{C}$.

SYMBOL	PARAMETER	CONDITIONS	MIN.	TYP.	MAX.	UNIT
V_{DD}	Supply voltage for control logic	Please refer to Fig. 13 for DC power-up sequence.	2.7	5.0	5.5	V
$V_{DD}-V_{EE}$	LCD bias voltage	Note 1.	8		20	
V_{IL}	Input LOW voltage of input pins	DI1~SDI/DI4, CP, LOAD, CDI, P/S, M, DISPOFF	0		$0.2V_{DD}$	V
V_{IH}	Input HIGH voltage of input pins	DI1~SDI/DI4, CP, LOAD, CDI, P/S, M, DISPOFF	$0.8V_{DD}$		V_{DD}	V
I_{IL}	Input LOW leakage current of input pins (i. e. Reverse leakage current of input ESD protection diode)	$V_{IN}=V_{SS}$, LOAD, CP, CDI, P/S, DI1~SDI/DI4, M, DISPOFF			1	μA
I_{IH}	Input HIGH leakage current of input pins (i. e. Reverse leakage current of input protection diode)	$V_{IN}=V_{DD}$, LOAD, CP, CDI, P/S, DI1~SDI/DI4, M, DISPOFF			1	μA
V_{OL}	Output LOW voltage level of the CDO pin	$I_{OL}=400\mu\text{A}$	0.0		0.4	V
V_{OH}	Output HIGH voltage level of the CDO pin	$I_{OH}=-400\mu\text{A}$	$V_{DD}-0.4$		V_{DD}	V
I_{STBY}	Standby current	Note 2.			200	μA
I_{SS}	Operating current (V_{DD} to V_{SS})	Note 3.			1.0	mA
I_{EE}	Operating current (V_{DD} to V_{EE})	Note 4.			0.1	mA
C_i	Input capacitance of the CP pin	The CP clock frequency is 3.3 MHz.		5.0		pF
R_{ON}	Driver ON resistance at $V_{LCD}=18\text{ V}$ (HV transmission transistors of O1~O80)	Note 5.		2.0	4.0	$\text{K}\Omega$

Notes:

1. The condition $V_{DD} \geq V1 > V3 > V4 > V_{EE}$ must always be met.
2. $CDI=V_{DD}$, $V_{DD}-V_{EE}=18\text{ V}$, $CP=3.3\text{ MHz}$, Output unloaded; measured at the V_{SS} pin.
3. Condition for the measurement: $V_{LCD}=V_{DD}-V_{EE}=18\text{ V}$, $CP=3.3\text{ MHz}$, $LOAD=5.156\text{ KHz}$, $M=52\text{ Hz}$. This is the current flowing from V_{DD} to V_{SS} , measured at the V_{SS} pin.
4. Condition for the measurement: $V_{LCD}=V_{DD}-V_{EE}=18\text{ V}$, $CP=3.3\text{ MHz}$, $LOAD=5.156\text{ KHz}$, $M=52\text{ Hz}$. This is the current flowing from V_{DD} to V_{EE} , measured at the V_{EE} pin.
5. Condition for the measurement: $V_{DD}-V_{EE}=18\text{ V}$, $|V_{DE}-V_O|=0.25\text{ V}$, where $V_{DE}=\text{one of } V1, V3, V4, \text{ or } V_{EE}$. $V1=V_{DD}$, $V3=(9/11) \times (V_{DD}-V_{EE})$, $V4=(2/11) \times (V_{DD}-V_{EE})$. For the driver circuits (O1~O80), please refer to Section 13, Pin Circuits.

80-Segment Dot-matrix STN LCD Driver

7 AC CHARACTERISTICS

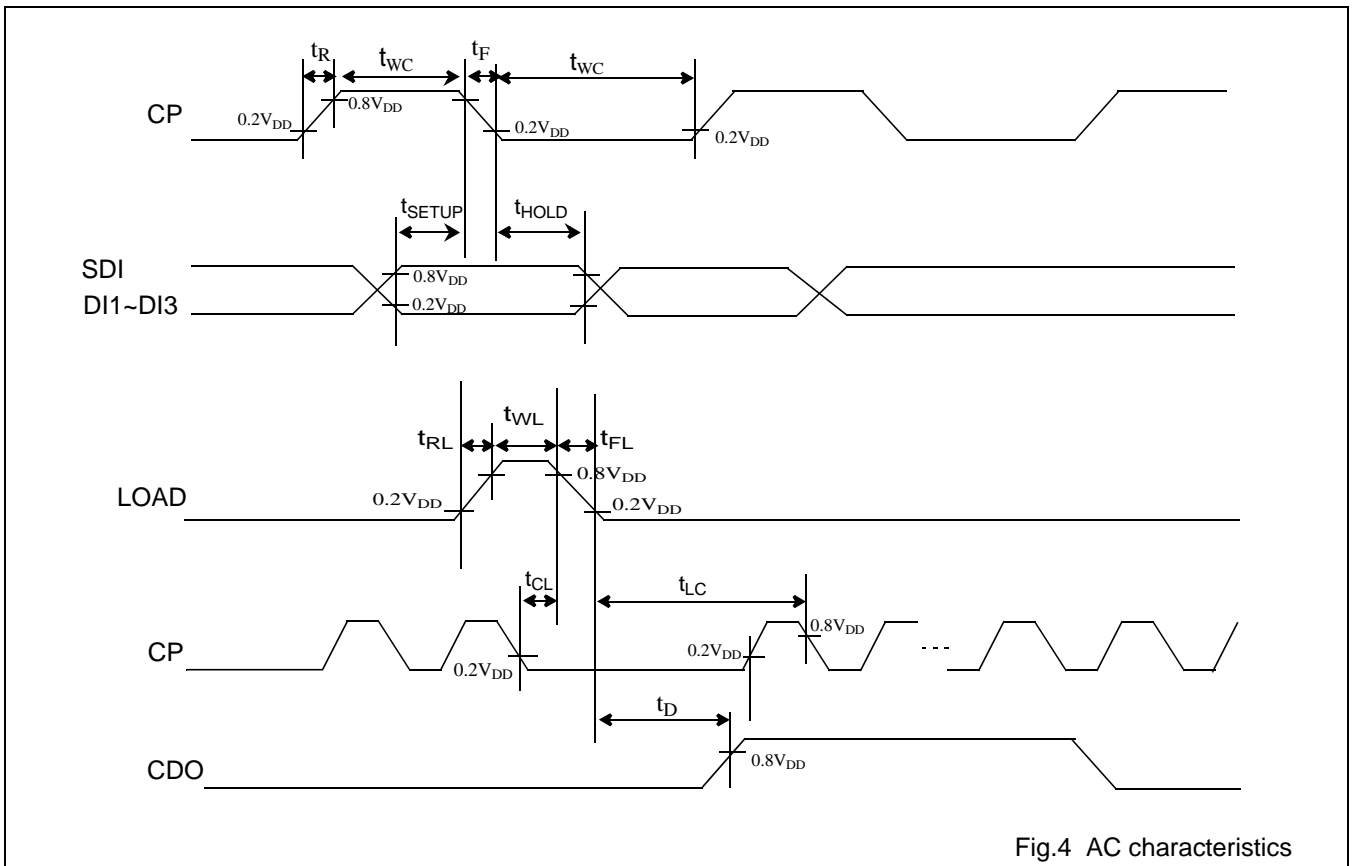

Fig.4 AC characteristics

Table 7 AC Characteristics

$V_{DD} = 5 V \pm 10\%$; $V_{SS} = 0 V$; all voltages with respect to V_{SS} unless otherwise specified; $T_{amb} = 25 \pm 2 ^\circ C$.

SYMBOL	PARAMETER	CONDITIONS	MIN.	MAX.	UNIT
f_{CP}	CP clock frequency			3.6	MHz
T_{WC}	CP clock pulse width		90		ns
T_{WL}	LOAD clock pulse width		90		ns
t_{SETUP}	Input data setup time	DI1~SDI/DI4 data to the falling edge of the CP clock.	60		ns
t_{HOLD}	Input data hold time.	Falling edge of the CP clock to DI1~SDI/DI4 data change.	60		ns
t_{CL}	CP to LOAD		80		ns
t_{LC}	LOAD to CP		80		ns
t_R	CP rise time			40	ns
t_F	CP fall time			40	ns
t_{RL}	Load rise time			40	
t_{FL}	Load fall time			40	
t_D	Output delay time	the CDO pin, Load=30 pF.		180	ns

80-Segment Dot-matrix STN LCD Driver

8 OUTPUT TIMING DIAGRAM

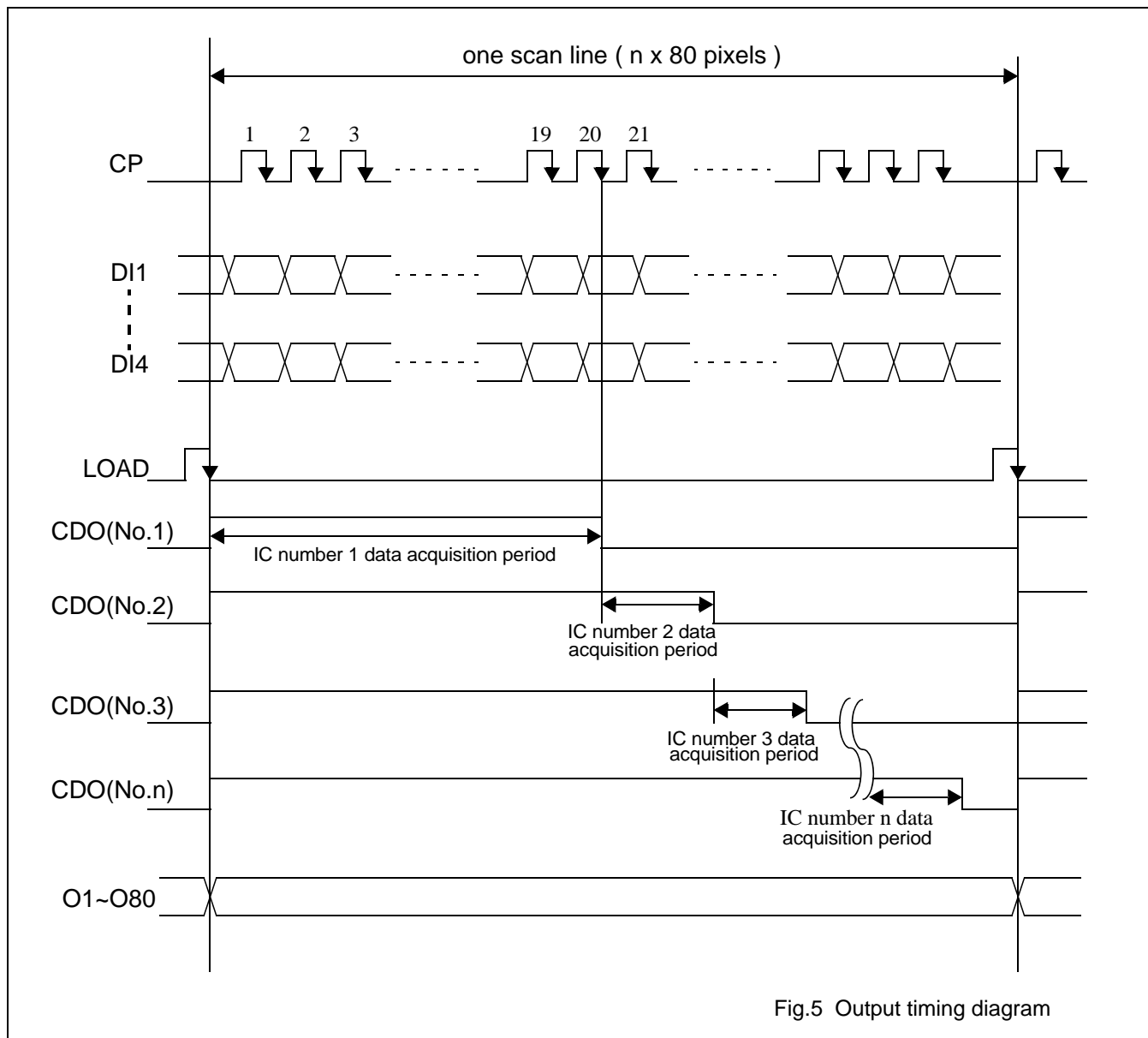

80-Segment Dot-matrix STN LCD Driver

9 TIMING CHART (1/240 DUTY, 1/16 BIAS)

9.1 1/240 duty timing chart

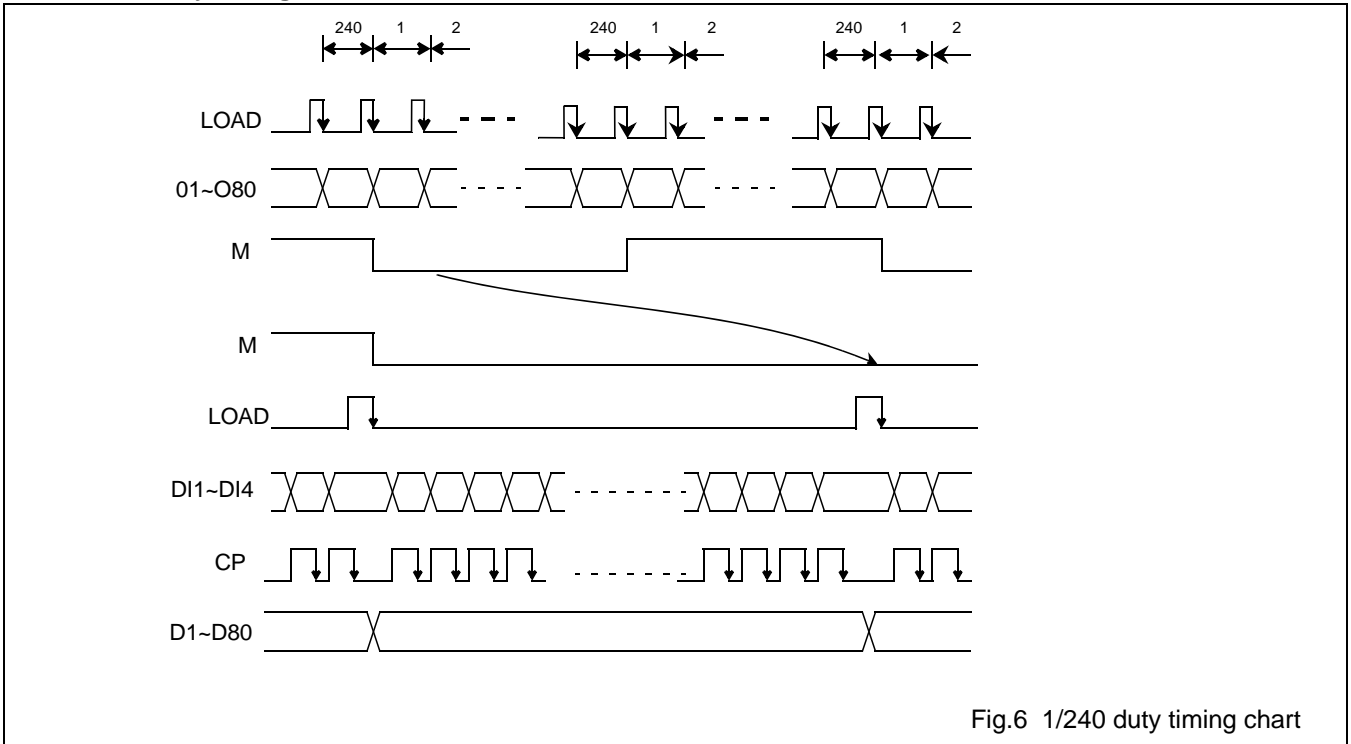

9.2 1/16 bias

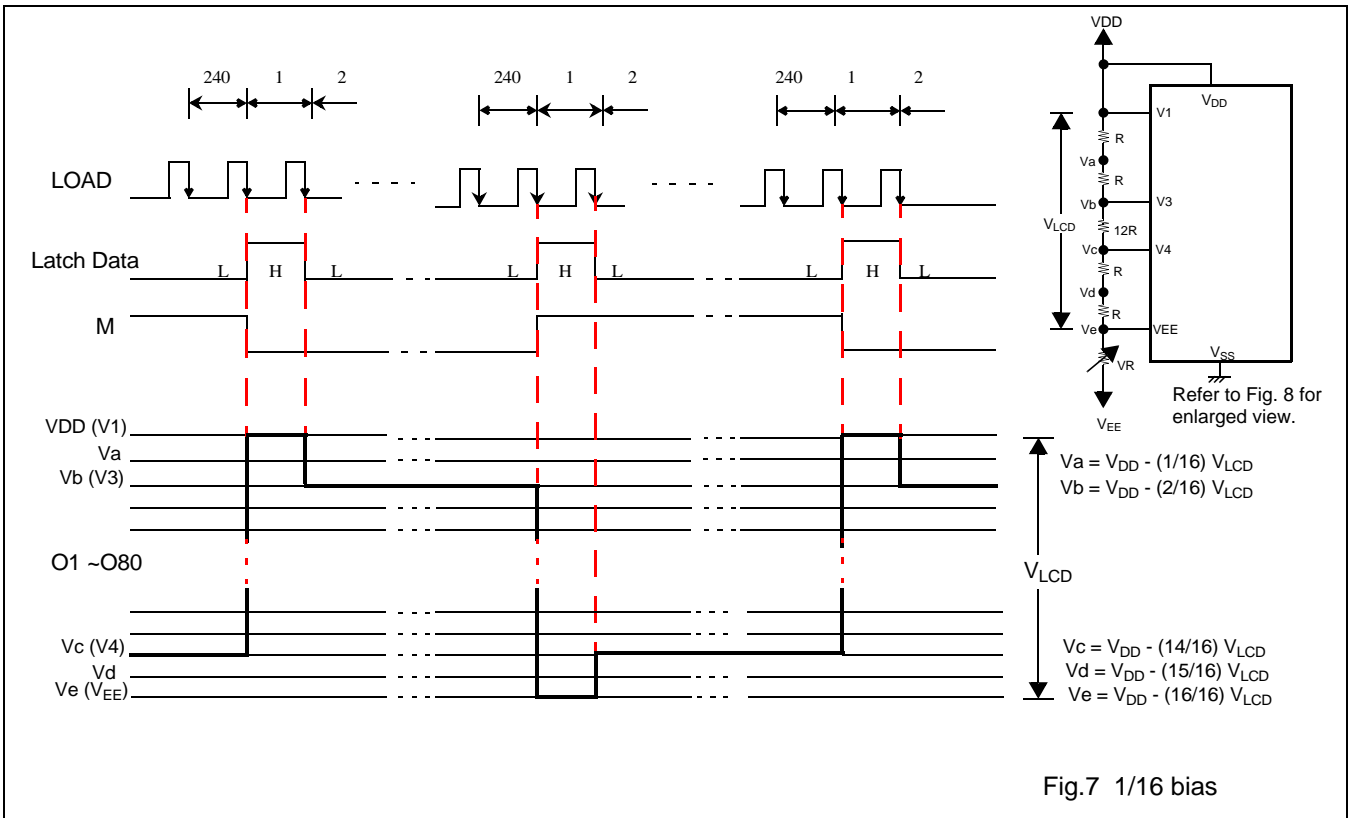

80-Segment Dot-matrix STN LCD Driver

9.3 Bias circuit

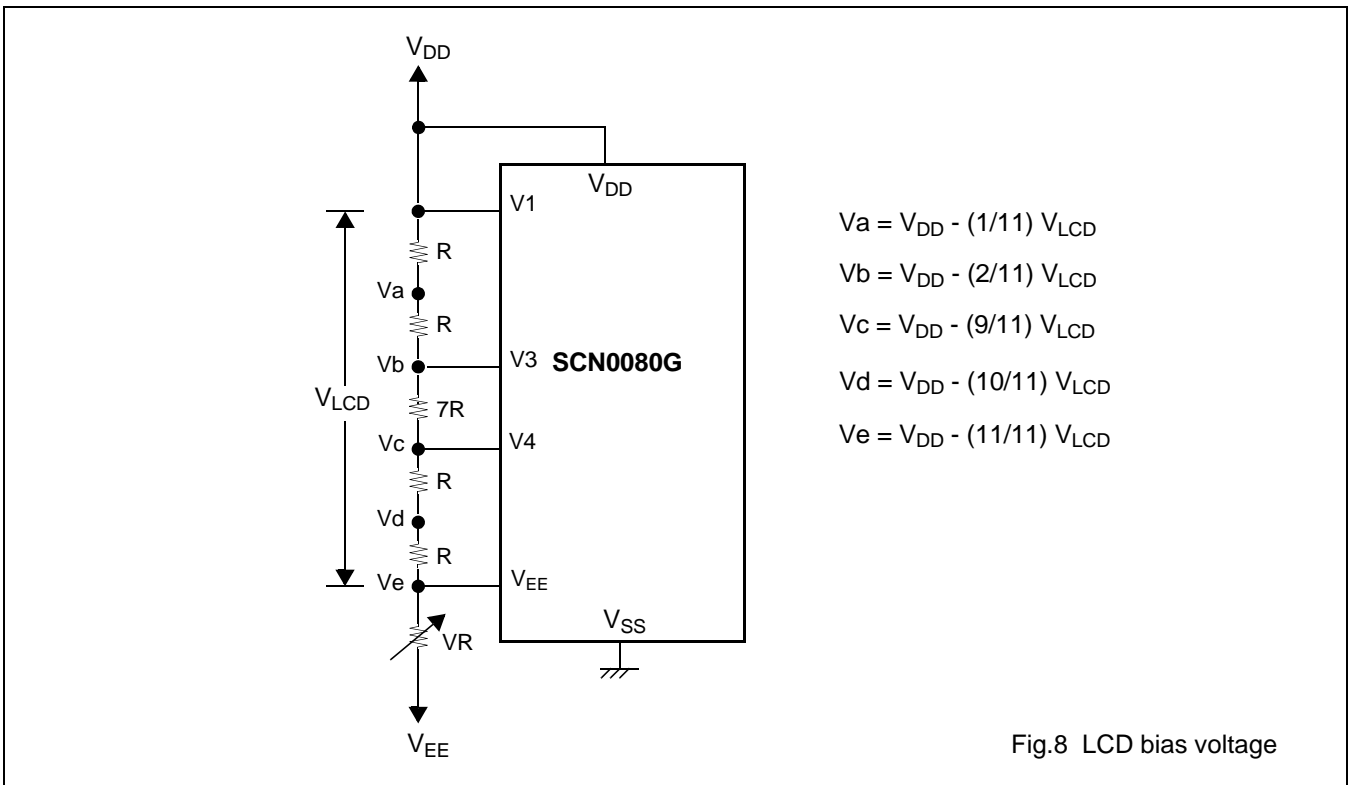

80-Segment Dot-matrix STN LCD Driver

10 100 X 240-PIXEL APPLICATION

The following diagram illustrates an example of using three SCN0080G (or SCN0080G_B) and two SCN6400G to design a 100 x 240-dots LCD panel. The duty cycle of the design is 1/100. For cascading application, Cascading Output (CDO) of the previous chip should be connected to the Cascading Input of the next chip.

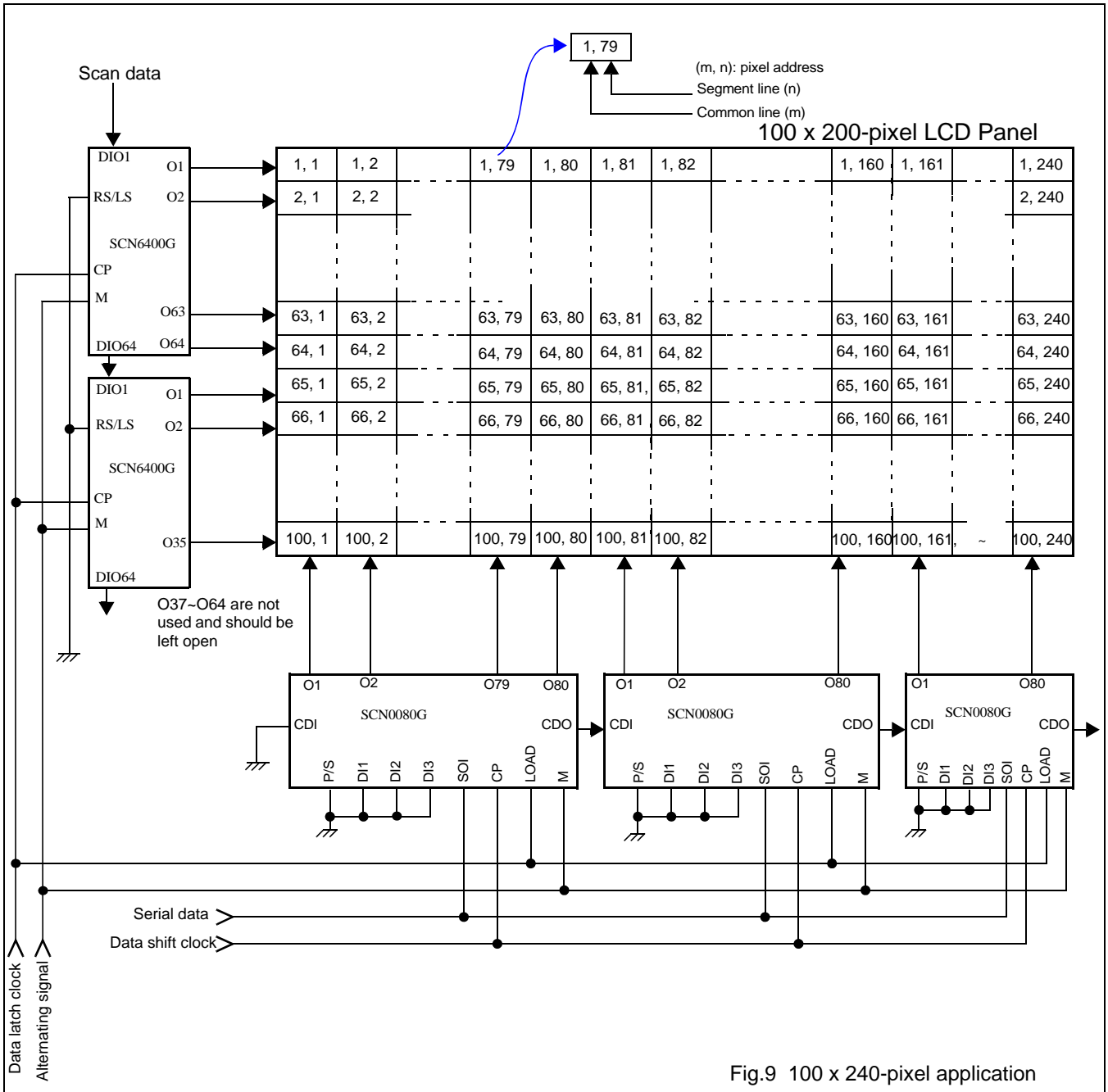

80-Segment Dot-matrix STN LCD Driver

11 TIMING DIAGRAM FOR 100 X 240-PIXEL APPLICATION

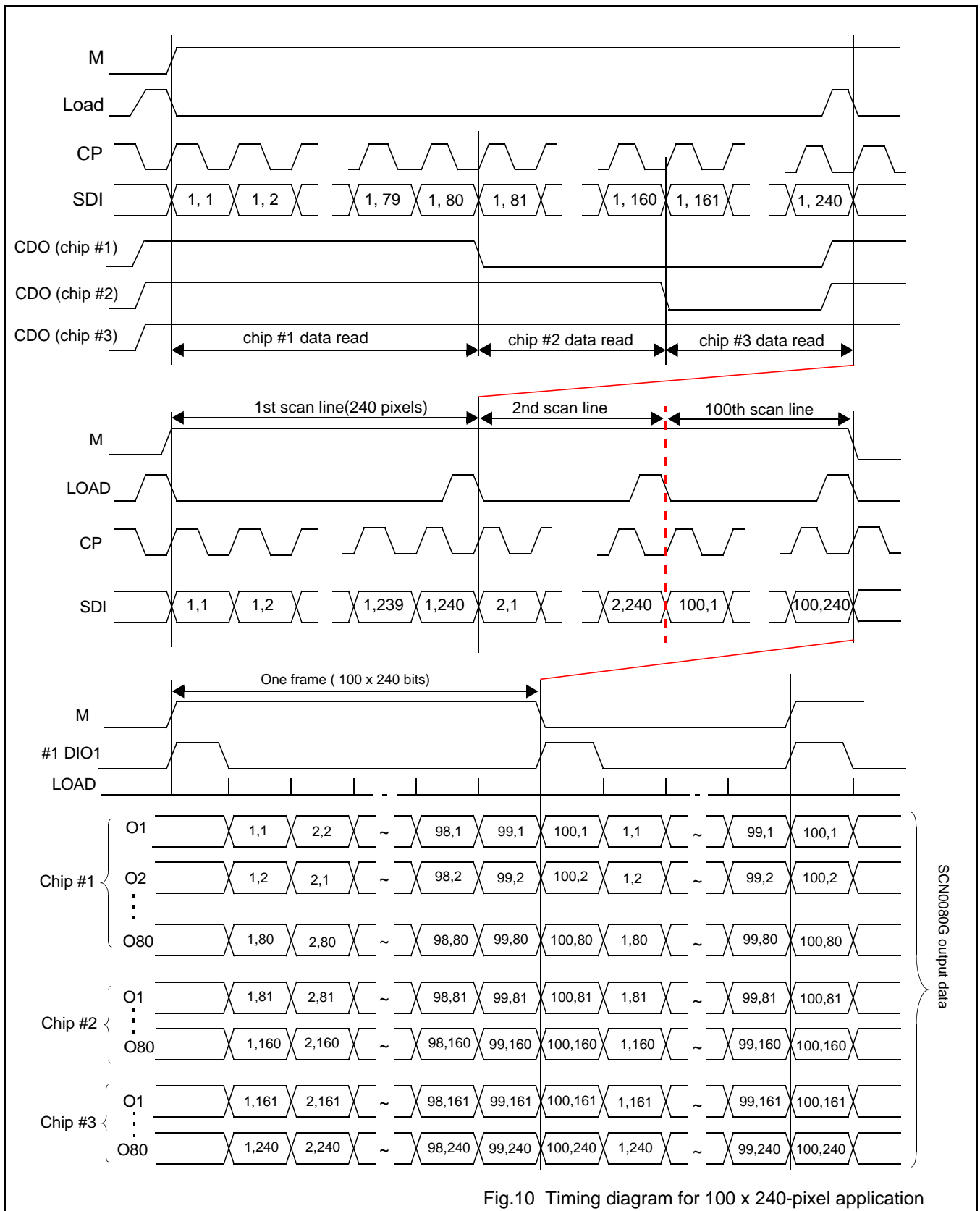
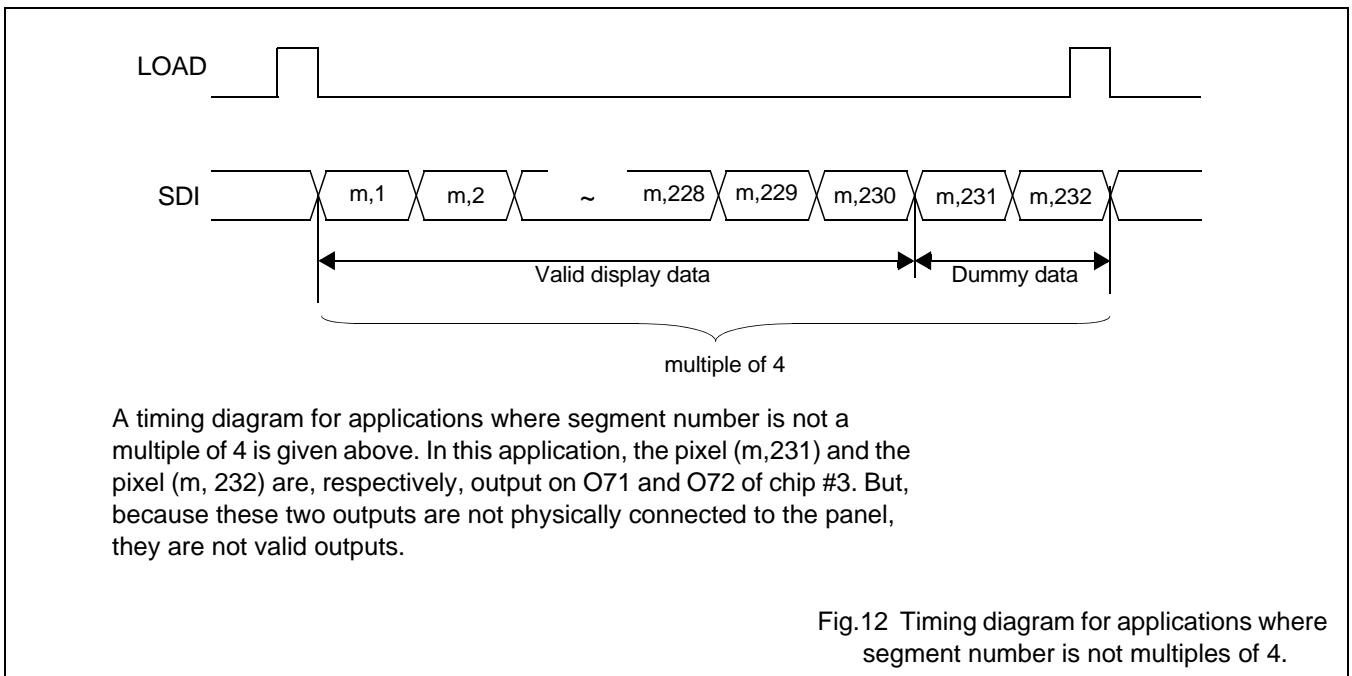
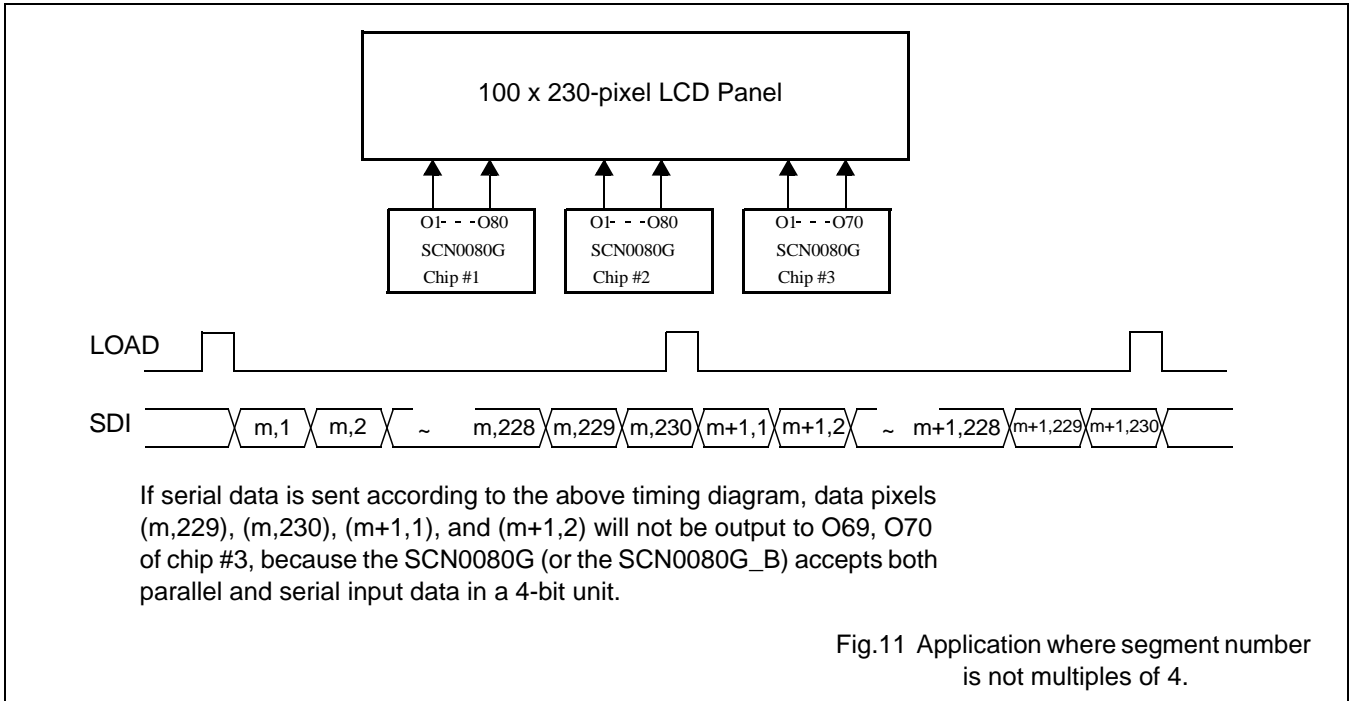

Fig.10 Timing diagram for 100 x 240-pixel application

80-Segment Dot-matrix STN LCD Driver

SCN0080G

12 APPLICATIONS WHERE SEGMENT DATA IS NOT A MULTIPLE OF 4



80-Segment Dot-matrix STN LCD Driver

SCN0080G

13 PIN CIRCUITS

Table 8 MOS-level schematics of all input, output, and I/O pins.

SYMBOL	Input/output	CIRCUIT	NOTES
CDO	Output		
CP, LOAD, DI1~SDI/DI4, P/S, M, CDI, DISPOFF	Inputs		
O1~O80, V1, V3, V4, VEE	Driver outputs, High voltage inputs		

80-Segment Dot-matrix STN LCD Driver

SCN0080G

14 APPLICATION NOTES

1. It is recommended that the following power-up sequence be followed to ensure reliable operation of your display system. As the ICs are fabricated in CMOS and there is intrinsic latch-up problem associated with any CMOS devices, proper power-up sequence can reduce the danger of triggering latch-up. When powering up the system, control logic power must be powered on first. When powering down the system, control logic must be shut off later than or at the same time with the LCD bias (V_{EE}).

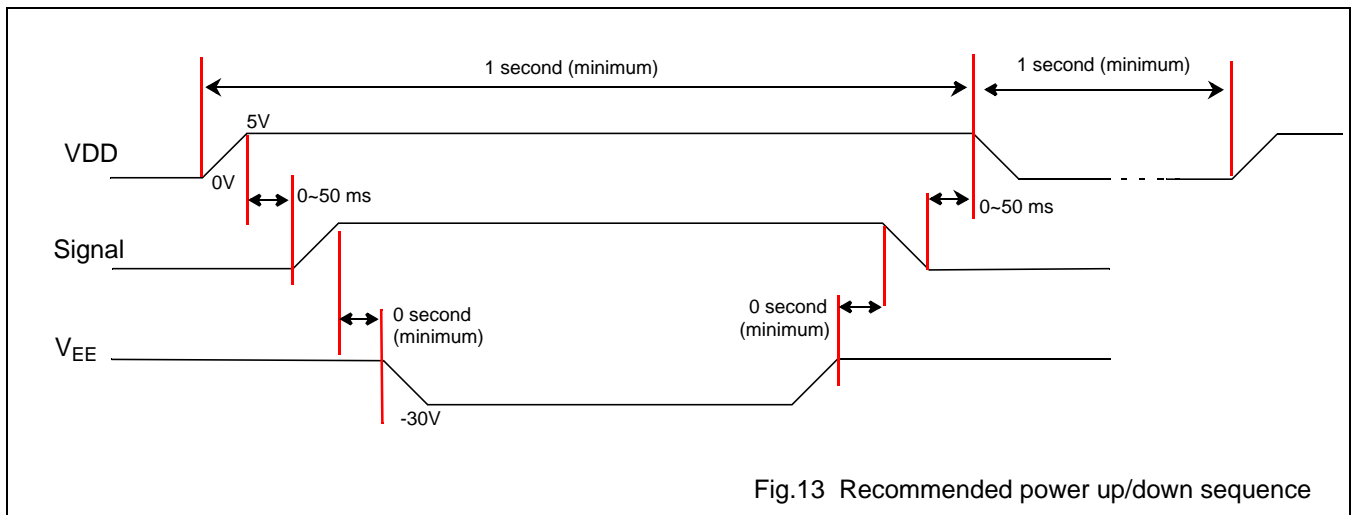

15 PACKAGE INFORMATION

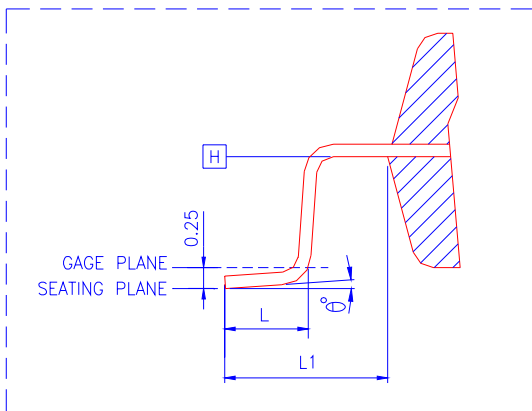
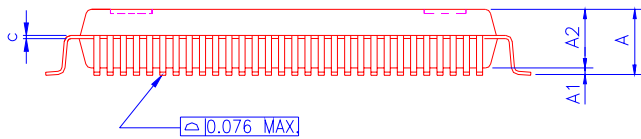
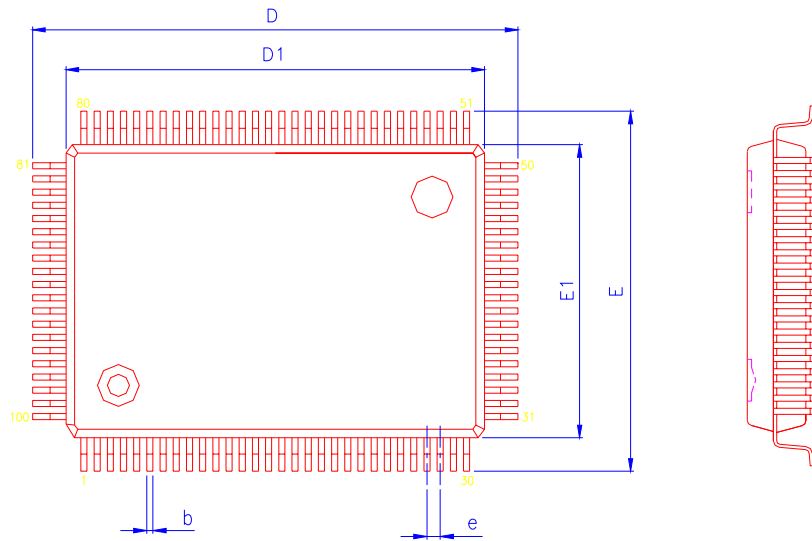

SYMBOLS	MIN.	NOM	MAX.
A	-	-	3.40
A1	0.25	-	0.50
A2	2.50	2.70	2.90
b	0.22	-	0.40
c	0.11	-	0.23
D	23.20 BASIC		
D1	20.00 BASIC		
e	0.65 BASIC		
E	17.20 BASIC		
E1	14.00 BASIC		
L	0.73	0.88	1.03
L1	-	1.60	-
θ°	0	-	7

UNIT : mm

NOTES:

1. JEDEC OUTLINE: MS-022 GC-1
2. DATUM PLANE \square IS LOCATED AT THE BOTTOM OF THE MOLD PARTING LINE COINCIDENT WITH WHERE THE LEAD EXITS THE BODY.
3. DIMENSIONS D1 AND E1 DO NOT INCLUDE MOLD PROTRUSION. ALLOWABLE PROTRUSION IS 0.25 mm PER SIDE. DIMENSIONS D1 AND E1 DO INCLUDE MOLD MISMATCH AND ARE DETERMINED AT DATUM PLANE \square .
4. DIMENSION b DOES NOT INCLUDE DAMBAR PROTRUSION.

SCN0080G

QFP100 Package Outline Drawing

80-Segment Dot-matrix STN LCD Driver

SCN0080G

16 SOLDERING

16.1 Introduction

There is no soldering method that is ideal for all IC packages. Wave soldering is often preferred when through-hole and surface mounted components are mixed on one printed-circuit board. However, wave soldering is not always suitable for surface mounted ICs, or for printed-circuits with high population densities. In these situations reflow soldering is often used.

This text gives a very brief insight to a complex technology. For more in-depth account of soldering ICs, please refer to dedicated reference materials.

16.2 Reflow soldering

Reflow soldering techniques are suitable for all QFP packages.

The choice of heating method may be influenced by larger plastic QFP packages (44 leads, or more). If infrared or vapour phase heating is used and the large packages are not absolutely dry (less than 0.1% moisture content by weight), vaporization of the small amount of moisture in them can cause cracking of the plastic body. For more information, please contact Avant for drypack information.

Reflow soldering requires solder paste (a suspension of fine solder particles, flux and binding agent) to be applied to the printed-circuit board by screen printing, stencilling or pressure-syringe dispensing before package placement.

Several techniques exist for reflowing; for example, thermal conduction by heated belt. Dwell times vary between 50 and 300 seconds depending on heating method. Typical reflow temperatures range from 215 to 250 °C.

Preheating is necessary to dry the paste and evaporate the binding agent. Preheating duration: 45 minutes at 45 °C.

16.3 Wave soldering

Wave soldering is **not** recommended for QFP packages. This is because of the likelihood of solder bridging due to closely-spaced leads and the possibility of incomplete solder penetration in multi-lead devices.

If wave soldering cannot be avoided, the following conditions must be observed:

- **A double-wave (a turbulent wave with high upward pressure followed by a smooth laminar wave) soldering technique should be used.**
- **The footprint must be at an angle of 45° to the board direction and must incorporate solder thieves downstream and at the side corners.**

During placement and before soldering, the package must be fixed with a droplet of adhesive. The adhesive can be applied by screen printing, pin transfer or syringe dispensing. The package can be soldered after the adhesive is cured.

Maximum permissible solder temperature is 260 °C, and maximum duration of package immersion in solder is 10 seconds, if cooled to less than 150 °C within 6 seconds. Typical dwell time is 4 seconds at 250 °C.

A mildly-activated flux will eliminate the need for removal of corrosive residues in most applications.

16.4 Repairing soldered joints

Fix the component by first soldering two diagonally- opposite end leads. Use only a low voltage soldering iron (less than 24 V) applied to the flat part of the lead. Contact time must be limited to 10 seconds at up to 300 °C. When using a dedicated tool, all other leads can be soldered in one operation within 2 to 5 seconds between 270 and 320 °C.

80-Segment Dot-matrix STN LCD Driver**SCN0080G**

17 LIFE SUPPORT APPLICATIONS

Avant products are not designed for use in life support appliances, devices, or systems where malfunction of these products may leads to personal injury. Avant customers using or selling these products for use in such applications do so at their own risk and agree to fully indemnify Avant for any damages resulting from such improper use or sale.